



TruMatic:

The perfect
combination.

Combining forces to achieve success.

Contents

Combining forces to achieve success. _____	2
Profiting from versatility. _____	4
Intelligent punching. _____	6
Punching Tools and Accessories. _____	7
TruMatic 3000 _____	8
TruMatic 3000 fiber _____	12
TruMatic 6000 _____	16
TruMatic 7000 _____	20
Components that pay off. _____	24
Programmed for success. _____	26
TruServices: Serve like no other. _____	27

TruMatic machines combine all the benefits of punching and laser processing. They enable you to produce a broad range of parts and handle even the most challenging jobs successfully. The punching head performs standard contouring and forming tasks, while complex contours are cut by the laser.

In 1979, TRUMPF became the first company to offer this combined technology to its customers. We have been building our own lasers for the industrial manufacturing industry since 1985 and have steadily established ourselves as a world leader in this sector.

TruMatic: Benefits at a glance.

- 1 Enhancing your capabilities through a mix of technologies.
- 2 Standard contouring and forming tasks are performed by the punching head.
- 3 The laser produces high-quality results for flowing and irregular contours.
- 4 Exceptional part quality.
- 5 Customized automation solutions.



TruMatic 3000

Compact thin-sheet-processing machine. This highly versatile, small-footprint machine makes it economical to process medium-sized sheets up to 4 mm thickness – even when operating below capacity.



TruMatic 6000

Rugged, all-round machine. This highly productive powerhouse is designed for both medium and large sheets and caters to all applications up to a sheet thickness of 8 mm.



TruMatic 7000

Productive high-end machine. Dynamic, scratch-free and fast – this top-rated combination machine fulfills the most stringent requirements with regard to productivity and part quality.

Profiting from versatility.

Standard contouring and forming tasks are performed by the punching head.



In addition to punching holes, you can produce three-dimensional contours such as brackets, threads and other forms. The electro-hydraulic punching head takes complete charge of processing your parts, eliminating the need for most downstream processing steps. Other benefits include:

- Versatile and cost-efficient thanks to 360° tool rotation.
- Produces a wide range of forms.
- High-speed processing.
- Top-notch punch contours.
- Fast changeover times.

The laser produces high-quality results for flowing and irregular contours.



Nothing beats lasers when it comes to cutting high-grade outer contours and intricate inner contours. With the slimline laser head of a TruMatic, you can cut right next to formed areas – or even cut on top of them. Controlline maintains a constant distance between the sheet and the cutting nozzle, resulting in a highly reliable process for fabricating even the most unusual geometries.

- Our lasers provide extraordinary versatility.
- Excellent cut quality.
- Sheets up to 8 mm thickness.
- Intricate contours.
- Our lasers are extremely energy-efficient.

Stable yet easily accessible.



All TruMatic machines are manufactured in an open C-frame design which gives you access to both the machine and the work-piece from three sides. With this configuration there is plenty of room for both manual and automated loading and unloading. Our machines are extraordinarily stable, ensuring high accuracy levels and virtually scratch-free parts.

- Machine is easily accessible from three sides.
- High accuracy levels.
- Scratch-free workpieces.
- High-speed unloading through parts chute.
- Modular automation.

Intelligent punching.

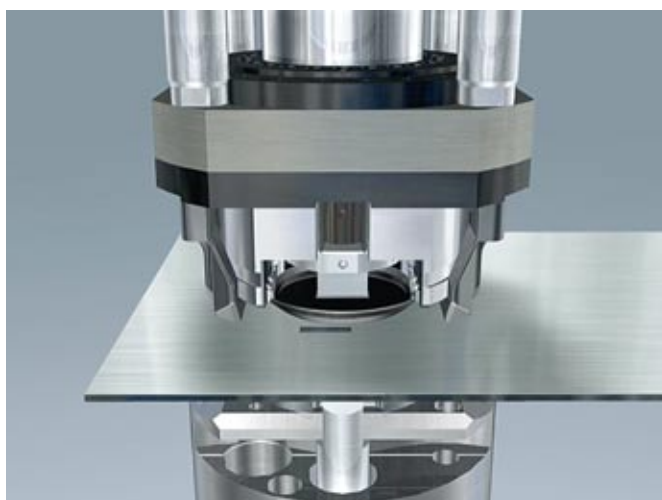

The wear-free ram guidance system combined with the mechanism that actively retracts the die ensures accurate results and maximum process reliability.



Thanks to 360° rotation, you can punch at whatever angle you like.

Versatile and cost-efficient thanks to 360° tool rotation.

Tools fit snugly into the punching head. One of the greatest advantages of the head design is that it can rotate any tool to the angle that is required, regardless of the tool's shape, size or position in the magazine.

Benefits of 360° rotation at a glance.

- Ability to position tools at any angle.
- Easily programmed.
- More efficient use of materials thanks to versatile sheet layout.
- Fast changeover times.
- Low tool costs.

Punching Tools and Accessories.

Wide selection of high-quality Punching Tools.

For the last 40 years, TRUMPF has provided its customers with original, top-quality punching tools – and a whole lot more. We offer the widest selection of tools on the market.

- **Punching Tools:** Whatever geometries or cutouts you are looking to produce, TRUMPF has the right tool for you.
- **Forming Tools:** You can achieve a wide variety of forming solutions with plastic deformation. TRUMPF forming tools are designed to enable complete processing of the sheet on a single machine.
- **Roller Tools:** Roller technology makes forming and cutting operations even faster – and 360° rotation makes it possible to fabricate just about any contour.
- **Embossing and Marking Tools:** Whether you are looking to inscribe serial numbers, the year of manufacture or your corporate logo, we can provide the tools you need for fast and efficient embossing and marking.
- **Tools for special purposes:** We can also supply tailor-made tools for special operations, such as deburring tools capable of producing high-quality edges. Our specialists can also develop customized punching tools according to your precise specifications. Thanks to our in-house manufacturing facilities and intensive testing, top-notch results are guaranteed. Custom punching tools can be delivered within a matter of days.
- **Tooling Accessories:** Tooling accessories make set-up and maintenance easier and increase the service life of your tools. Making sure your punching tools are precisely calibrated and sharpened regularly also plays an essential role in achieving optimum results.
- **Integrated Tool Management:** This system helps you keep track of your tools at all times, enabling you to optimize set-up processes and tool deployment.

For more information on punching tools and accessories, please visit www.trumpf-machines.com/Services



Roller deburring tool



Deburring MultiTool

TruMatic 3000

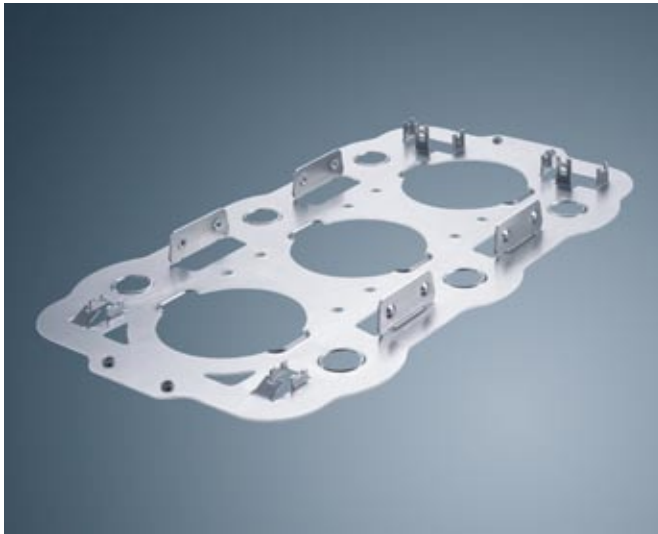

Mild steel St37, 1.0 mm

Technologies used: laser cutting, punching, stamping, tapping, forming, cupping, MultiBend.



Mild steel St37, 1.0 mm

Technologies used: laser cutting, punching, roller beading, roller offsetting, stamping, forming.

TruMatic 3000:
Benefits at a glance.

- 1 Compact medium format machine.
- 2 Processing of thin sheets up to a thickness of 4 mm.
- 3 High-quality beam ensures exceptional edge quality.
- 4 Energy-efficient TruCoax laser.
- 5 Cost-effective solution – even for small volumes.



Mild steel St37, 1.0 mm

Technologies used: laser cutting, punching, roller offsetting, stamping.



TruCoax 2000 laser – a great choice for achieving perfect part quality at high feed rates.

Compact thin-sheet-processing machine.

This small-footprint machine provides a major boost to the range of parts you can process. Its greatest strength lies in the complete processing of medium-sized sheets up to 4 mm thickness.

The TruMatic 3000 handles workpieces gently and carefully. Its pneumatic spring-loaded rollers guide the sheets over the die leaving them virtually scratch-free. The brush tables included in the system protect sheet surface quality.

The TruCoax 2000 laser requires minimal maintenance. Thanks to the use of diffusion cooling, it uses so little gas that one premix gas bottle will last for approximately one year. In addition, the superb beam quality of the TruCoax 2000 laser ensures high-precision cutting results and exceptional edge quality.



Technical specifications:

Work area (X x Y)

Combined punch/laser operation	2175 x 1250 mm ^[1]
Punching operation	2500 x 1250 mm
Laser operation	2500 x 1250 mm

Capacity

Laser power	2000 W
Max. sheet thickness	4 mm
Max. punching force	165 kN
Max. workpiece weight	120 kg

Speed

X axis	90 m/min
Y axis	60 m/min
Simultaneous (X and Y)	108 m/min
C axis (punching)	60 rpm
C axis (tapping)	180 rpm
Max. stroke rate (punching) (E= 1 mm)	600 1/min
Max. stroke rate (marking)	1300 1/min



Tools	
Linear magazine	18 tools with 2 clamps
	17 tools with 3 clamps
No. with MultiTool	18–180
MultiTool	5/10 station
Tool change time	2.2–4.4 s
Accuracy ^[2]	
Positioning accuracy Pa	± 0.1 mm
Repeatability Ps	± 0.03 mm
TRUMPF CNC control	BOSCH PNC-P
Programmable parts chute	
Max. part size	300 x 500 mm
Dimensions ^[3]	
Space requirements	6825 x 6325 mm
Height	2500 mm

Laser data	TruCoax 2000
Max. power	2000 W
Adjustable power range in 1% steps	100–2000 W
Wavelength	10.6 µm
Beam mode	TEM ₀₀
Cycle frequency	100 Hz – 10 kHz
Laser gas	Premix gas
Electrical power consumption of entire system	55 kVA

^[1] Without repositioning.

^[2] Achievable workpiece accuracy depends on various factors, including workpiece type, its pretreatment, sheet size and position within the work area. In accordance with VDI/DGQ 3441. Measuring length 1 m.

^[3] Approximate values. Exact specifications can be found in the most recent installation plan.

TruMatic 3000 fiber

Compact thin-sheet-processing machine.

The TruMatic 3000 fiber is a combination machine with some remarkable features. It combines three technologies within a single system: laser cutting, laser welding and punching.

That makes it a true multiprocess machine. The punching head provides an economical means of performing standard contouring and forming tasks, while more intricate contours are cut with the laser. The laser can also be used in a separate system to create high-quality weld seams.

Your gain in efficiency: While the machine is punching, you can use the laser to weld, reducing idle time. You can also use your TruDisk for combination processing in one shift and for laser welding in the next.

TruMatic 3000 fiber:
Benefits at a glance.

- 1 Laser cutting, laser welding and punching in a single system.
- 2 Helps cut costs by making optimum use of the TruDisk laser.
- 3 Energy-efficient solid-state laser.
- 4 Compact and flexible incorporation within the LaserNetwork.
- 5 High part quality and economical thin sheet processing.



Stainless steel VA, 1.5 mm

Technologies used: laser cutting, laser welding.

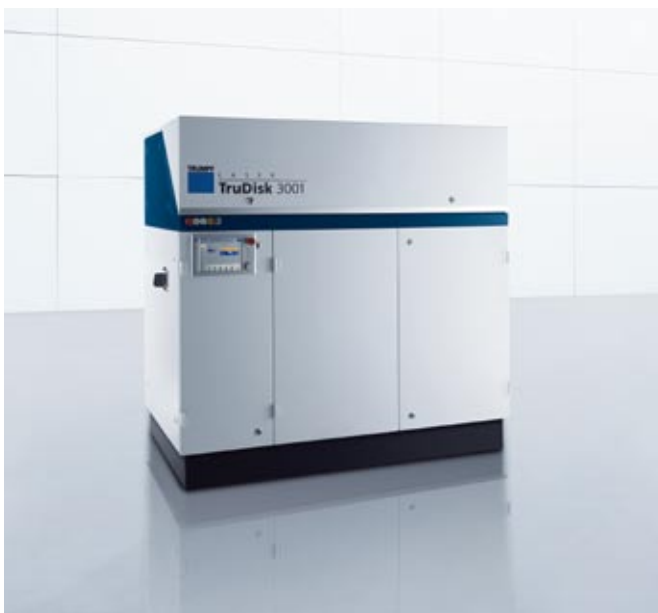

Energy-efficient thin sheet processing: the fiber-guided TruDisk solid-state laser.

TruDisk – your thin sheet specialist.

The laser beam of the TruDisk solid-state laser is fiber-guided which makes the laser extremely flexible in setup. It also offers the following key benefits:

- High energy efficiency.
- Low cutting costs per meter in thin sheets.
- Can be deployed across multiple stations.

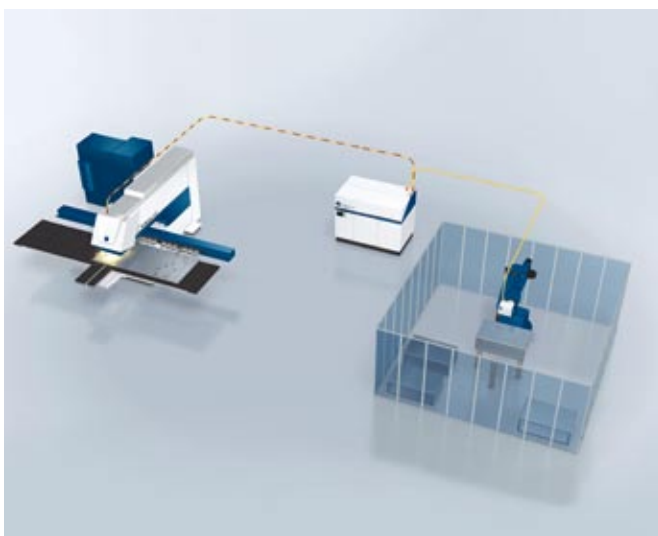

Optimum capacity utilization: one laser for two machines.

TRUMPF LaserNetwork – always working at full capacity.

The TruMatic 3000 fiber ensures that your TruDisk laser is put to optimum use within the LaserNetwork. While the machine is punching, you can use the laser for welding. Therefore, you benefit in a number of ways:

- You make better use of the laser source's full capacity.
- Lower cost per part thanks to reduced hourly machine rate.
- Inexpensive entry into laser welding.



Technical specifications:

Work area (X x Y)	
Combined punch/laser operation	2175 x 1250 mm ⁽¹⁾
Punching operation	2500 x 1250 mm
Laser operation	2500 x 1250 mm
Capacity	
Laser power	3000 W
Max. sheet thickness	4 mm
Max. punching force	165 kN
Max. workpiece weight	120 kg
Speed	
X axis	90 m/min
Y axis	60 m/min
Simultaneous (X and Y)	108 m/min
C axis (punching)	60 rpm
C axis (tapping)	180 rpm
Max. stroke rate punching (E= 1 mm)	600 1/min
Max. stroke rate (marking)	1300 1/min



Tools	
Linear magazine	18 tools with 2 clamps
	17 tools with 3 clamps
No. with MultiTool	18–180
MultiTool	5/10 station
Tool change time	2.2–4.4 s
Accuracy ^[2]	
Positioning accuracy Pa	± 0.1 mm
Repeatability Ps	± 0.03 mm
TRUMPF CNC control	BOSCH PNC-P
Programmable parts chute	
Max. part size	300 x 500 mm
Dimensions ^[3]	
Space requirements	6825 x 6325 mm
Height	2500 mm

Laser data	TruDisk 3001
Max. power	3000 W
Adjustable power range in 1% steps	100–3000 W
Wavelength	1.03 µm
Fiber diameter	100 µm
Cycle frequency	100 Hz–10 kHz
Laser active medium	Yb:YAG

^[1] Without repositioning.

^[2] Achievable workpiece accuracy depends on various factors, including workpiece type, its pretreatment, sheet size and position within the work area. In accordance with VDI/DGQ 3441. Measuring length 1 m.

^[3] Approximate values. Exact specifications can be found in the most recent installation plan.

TruMatic 6000

Rugged, all-round machine.



Compact and reliable: the TruFlow laser.

TruMatic 6000:
Benefits at a glance.

- 1 Versatile processing of sheets up to 8 mm thickness.
- 2 Available in medium- and large-format versions.
- 3 A highly productive powerhouse.
- 4 Parts chute for unloading.
- 5 Comprehensive automation concept.

The TruMatic 6000 is an extremely versatile machine that employs sophisticated laser and punching technology. With its powerful and efficient punching head and laser, this is a machine that guarantees high productivity.

It enables you to perform a full range of complete, self-contained contouring tasks quickly and accurately, which means that even small lot sizes can be produced economically.

Proven laser technology.

The TruMatic 6000 comes with the choice of three different TruFlow lasers (2,000, 2,700 or 3,200 watts). TruFlow lasers boast excellent reliability and cost-efficient operation.

Quick-action punching head.

Short tool changeover times and high stroke rates make the TruMatic 6000's punching head an ultrafast solution. It punches at a rate of 900 strokes per minute and marks at 2,800 strokes per minute.

Reliable unloading mechanism.

Pieces punched or cut out by the machine can be quickly unloaded through two chutes which are monitored by sensors. That means you can reliably discharge parts up to 500 x 500 mm while directly unloading small parts of up to 50 x 80 mm. In the laser station, an ejector cylinder helps to ensure reliable loading and unloading.



Electro-galvanized steel St37, 1.0 mm

Technologies used: laser cutting, punching, extrusion, roller offsetting, MultiBend, double bridge.

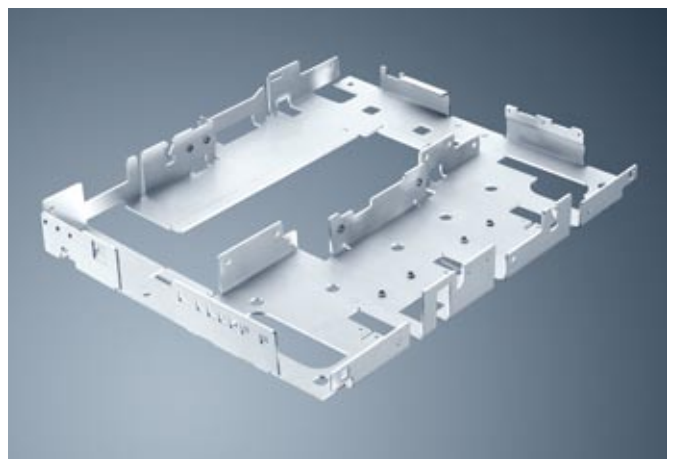

Electro-galvanized steel St37, 1.5 mm

Technologies used: laser cutting, punching, MultiBend, marking, tapping, projection welding, stamping.

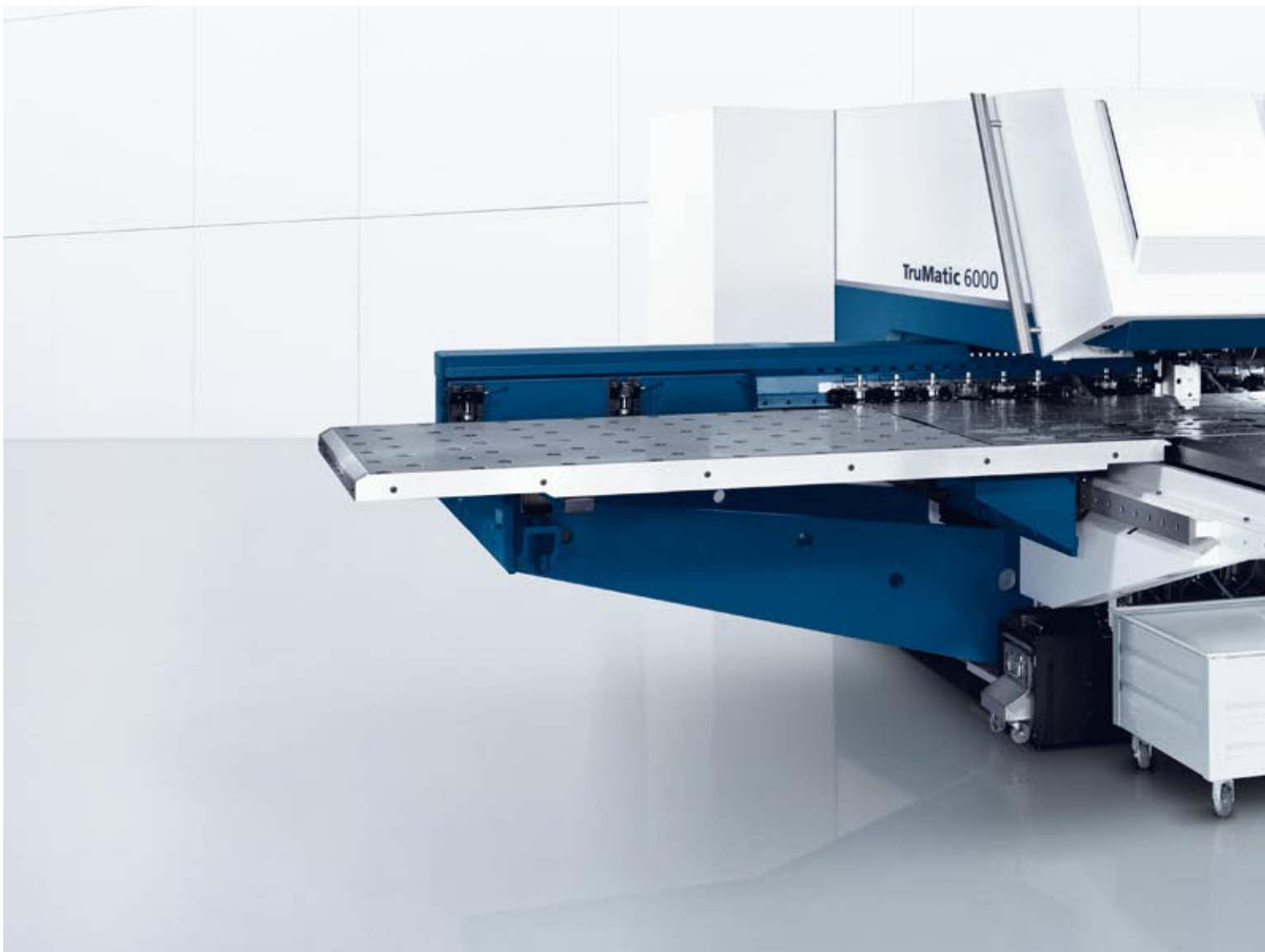

Technical specifications:

	TruMatic 6000 medium format	TruMatic 6000 large format
Work area (X x Y)		
Combined punch/ laser operation	2500 x 1250 mm	3050 x 1550 mm ^[1]
Punching operation	2500 x 1250 mm	3050 x 1600 mm
Laser operation	2500 x 1250 mm	3050 x 1600 mm
Capacity		
Laser power	2000 / 2700 / 3200 W	2000 / 2700 / 3200 W
Max. sheet thickness	8 mm	8 mm
Max. punching force	220 kN	220 kN
Active hold-down (programmable in steps)	4.5 – 20 kN	4.5 – 20 kN
Max. workpiece weight	200 kg	230 kg
Speed		
X axis	90 m/min	90 m/min
Y axis	60 m/min	60 m/min
Simultaneous (X and Y)	108 m/min	108 m/min

Speed	
C axis (punching)	
C axis (tapping)	
Max. stroke rate (punching) (E = 1 mm)	
Max. stroke rate (marking)	
Tools	
Linear magazine	
No. with MultiTool	
MultiTool	
Tool change time	
Accuracy^[2]	
Positioning accuracy Pa	
Repeatability Ps	



TruMatic 6000 medium format	TruMatic 6000 large format
60 rpm	60 rpm
330 rpm	330 rpm
900 1/min	900 1/min
2800 1/min	2800 1/min
19 tools with 2 clamps	18 tools with 3 clamps
19–190	18–180
5/10 station	5/10 station
0.7–6.5 s	0.7–6.5 s
± 0.10 mm	± 0.10 mm
± 0.03 mm	± 0.03 mm

	TruMatic 6000 medium format	TruMatic 6000 large format
TRUMPF CNC control	Siemens Sinumerik 840D	Siemens Sinumerik 840D
Programmable chute		
Max. part size for punch and laser	500 x 500 mm	500 x 500 mm
Dimensions^[3]		
Space requirements	7460 x 7000 mm	7460 x 7900 mm
Height	2500 mm	2500 mm
Weight	16000 kg	22500 kg
Electrical power consumption of the entire system		
TruFlow 2000	65 kVA	65 kVA
TruFlow 2700	73 kVA	73 kVA
TruFlow 3200	76 kVA	76 kVA

^[1] With repositioning.

^[2] Achievable workpiece accuracy depends on various factors, including workpiece type, its pretreatment, sheet size and position within the work area. In accordance with VDI/DGQ 3441. Measuring length 1 m.

^[3] Approximate values. Exact specifications can be found in the most recent installation plan.

TruMatic 7000

Productive high-end machine.

The TruMatic 7000 combines the advantages of punching and laser processing in an extremely cost-efficient package. It provides a fast and reliable process for fabricating scratch-free combination parts. In addition, the active die offers you highly versatile forming capabilities.

Intelligent automation.

A SheetMaster designed to cater to the top-notch performance of the TruMatic 7000 is available as an extra. It is extremely dynamic, reliable and versatile:

- Achieve high productivity with its dynamic operation and simultaneous unloading of up to 4 parts.
- Maintain superior process reliability with its versatile suction positioning and additional laser axis.
- Operate in unmanned shifts by using the single cutting head strategy and automatic nozzle changer.

TruMatic 7000: Benefits at a glance.

- 1 Highly dynamic solution.
- 2 Scratch-free punching and laser processing.
- 3 Unique forming capabilities.
- 4 Fast-action parts chute for unloading combination parts.
- 5 Efficient and powerful automation.



Active die: quality in a new dimension.

Scratch-free processing:

Move your sheet into position for punching and forming without scratching.

Advanced forming capabilities:

The active forming stroke from below enables you to achieve entirely new sizes and heights.

Optimized process reliability:

Reduces the risk of snagging or catching when cutting out large internal sections.

More efficient use of materials:

Significantly minimizes the clamp dead area during forming, which results in material savings.

More user-friendly:

Your machine is programmed more easily, quieter and requires less tool maintenance.

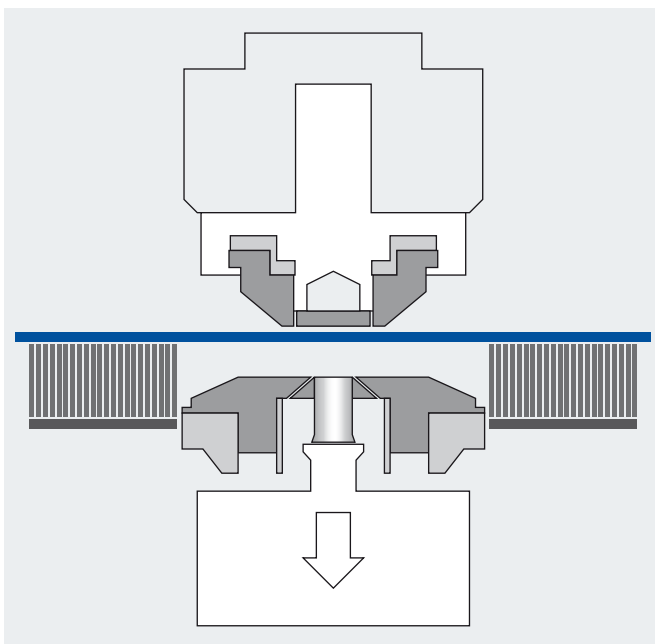

Scratch-free sheet positioning with the active die.

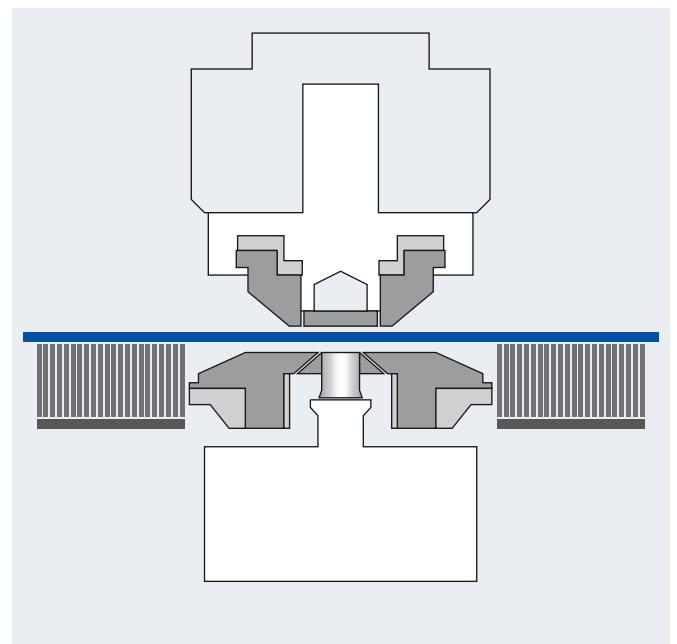

Sheet positioning with a conventional die.



Technical specifications:

	TruMatic 7000 medium format	TruMatic 7000 large format
Work area (X x Y)		
Combined punch/ laser operation	2500 x 1250 mm	3050 x 1550 mm ^[1]
Punching operation	2500 x 1250 mm	3050 x 1550 mm
Laser operation	2500 x 1250 mm	3050 x 1550 mm
Capacity		
Laser power	2700 / 3200 / 4000 W	2700 / 3200 / 4000 W
Max. sheet thickness	8 mm	8 mm
Max. punching force	220 kN	220 kN
Active presser foot (programmable in steps)	4.5 – 20 kN	4.5 – 20 kN
Max. workpiece weight	220 kg	280 kg
Speed		
X axis	100 m/min	100 m/min
Y axis	60 m/min	60 m/min
Simultaneous (X and Y)	116 m/min	116 m/min

^[1] With repositioning.

^[2] Achievable workpiece accuracy depends on various factors, including workpiece type, its pretreatment, sheet size and position within the work area. In accordance with VDI/DGQ 3441. Measuring length 1 m.

^[3] Approximate values. Exact specifications can be found in the most recent installation plan.

Speed
C axis (punching)
C axis (tapping)
Max. stroke rate (punching) (E = 1 mm)
Max. stroke rate (marking)
Tools
Linear magazine
No. with MultiTool
MultiTool
Tool change time
Accuracy^[2]
Positioning accuracy Pa
Repeatability Ps





TruMatic 7000 medium format	TruMatic 7000 large format
330 rpm	330 rpm
330 rpm	330 rpm
1200 1/min	1000 1/min
2800 1/min	2800 1/min
22 tools with 3 clamps	21 tools with 4 clamps
22–220	21–210
5/10 station	5/10 station
0.3–2.8 s	0.3–2.8 s
± 0.10 mm	± 0.10 mm
± 0.03 mm	± 0.03 mm

	TruMatic 7000 medium format	TruMatic 7000 large format
TRUMPF CNC control	Rexroth IndraMotion MTX	Rexroth IndraMotion MTX
Programmable chute		
Max. part size for punch and laser	500 x 500 mm	500 x 500 mm
Dimensions^[3]		
Space requirements	8000 x 6700 mm	8070 x 7650 mm
Height	2500 mm	2500 mm
Weight	24100 kg	24100 kg
Power consumption		
Average	16–70 kW	16–70 kW
Standby operation	ca. 1 kW	ca. 1 kW
Electrical power consumption of the entire system		
TruFlow 2700	73 kVA	73 kVA
TruFlow 3200	76 kVA	76 kVA
TruFlow 4000	87 kVA	87 kVA

Components that pay off.

Efficient, economical production through automation.

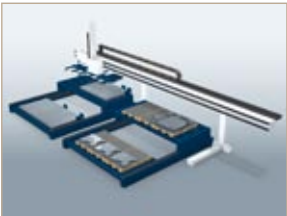
- Everything from a single source: there are no interface problems.
- Optimized material flow and enhanced process reliability boost productivity.
- Increase capacity by running highly automated multishift operations up to 24 hours a day.
- Careful material handling ensures more efficient material usage.
- Clearly organized storage gives you fast access to materials and saves space.

	SheetMaster	Cart systems	SortMaster Pallet	SortMaster Box
				
Compatible machines:				
TruMatic 3000	■	■	■	■
TruMatic 6000	■	■	■	■
TruMatic 7000	■	■	■	■

SheetMaster – Fast and reliable loading and unloading, stacking and sorting.

Cart systems – Double your loading and unloading capacity by deploying versatile storage and sorting solutions for raw materials and finished parts. Solutions with tracks and belt drives are available.

SortMaster Pallet – Sort and stack finished parts on up to six europallets.

SortMaster Box – Sort finished parts into four standardized, stackable containers.



GripMaster – Fast and reliable removal and stacking of sheet skeletons parallel to the loading process.

ShearMaster – Shredding of sheet skeletons during machining operations minimizes process costs in the manufacturing environment.

ToolMaster – Changes tools in less than nine seconds and increases capacity, making up to 70 tools available at once.

TruStore – Modular and upgradable storage and shelving system provides a well-organized, space-saving storage solution.

Storage solutions from Stopa – For special requirements we also offer highly customizable storage solutions in cooperation with our partner, Stopa.

GripMaster	ShearMaster	ToolMaster	TruStore	Stopa storage solutions
				
■	■		■	■
■	■	■	■	■
■	■	■	■	■

Programmed
for success.

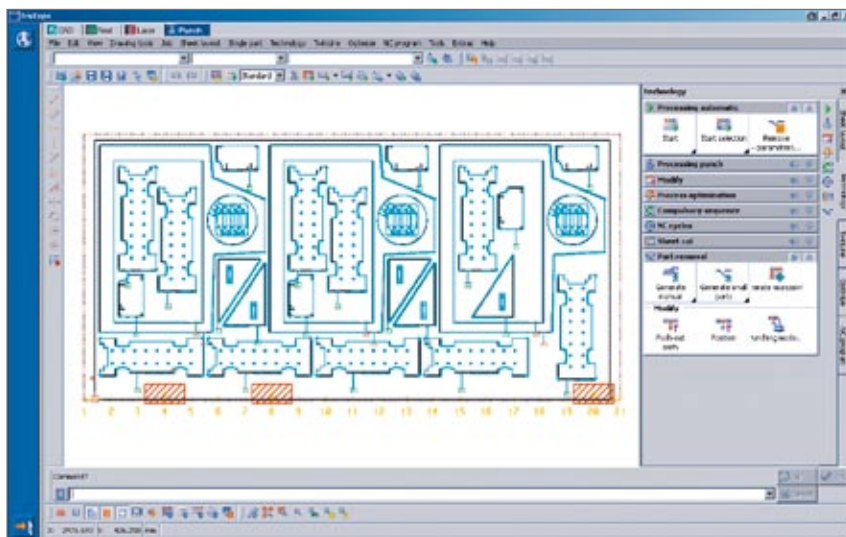

Our TruTops Punch programming software helps you take full advantage of the potential of our TruMatic machines. Automatic features enable fast and efficient programming, nesting solutions perfectly tailored to your specific requirements and careful management of scrap skeletons that ensures the best possible material usage. This impressive functionality is topped off with a user-friendly interface that includes powerful, yet easy-to-use simulation options.

TruTops Punch: Benefits at a glance.

- Superb process reliability and fast NC programs.
- Full control over part processing and process parameters.
- Integration in TRUMPF's overall concept – from design to production planning.
- Ergonomic and efficient operating concept.

TruServices:

Service like
no other.

Throughout the lifecycle of your machine.

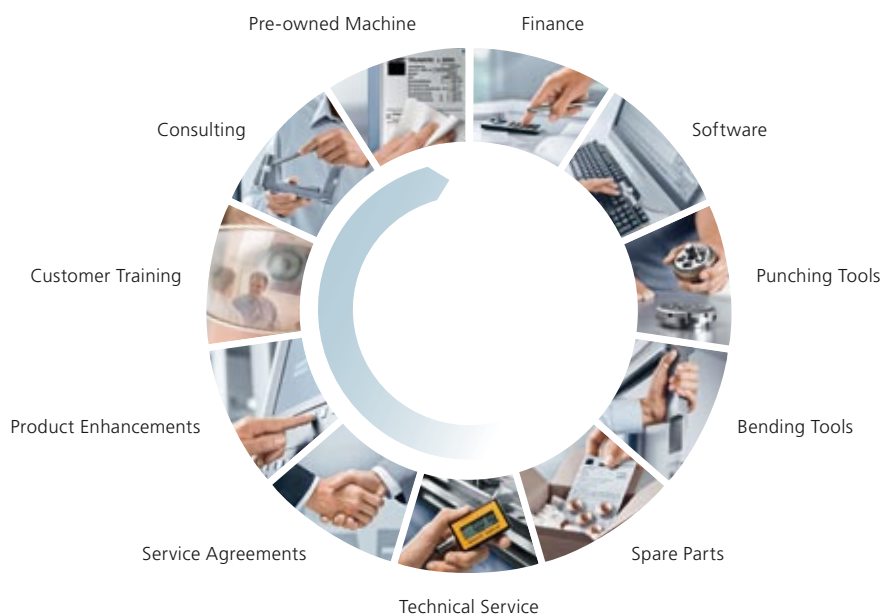

Regardless of the TRUMPF technology you use, you will always get the best service. And, thanks to TRUMPF's award-winning spare parts logistics, all parts can be shipped to you in the shortest time possible. TRUMPF Leasing offers you individual financing solutions quickly and without a lot of paperwork. Our service technicians are highly trained and always available when you need them. A Service Agreement is the ideal way of ensuring the best usability of your machine.

Should your requirements change, we have flexible upgrading options and technical innovations that will make your machine even better. Our broad range of training courses with experienced trainers and hands-on practice will also give you a head start in understanding and operating your machine.

You can find out more about our services at www.trumpf-machines.com/Services

The TRUMPF Group ranks among the world's leading manufacturers of production technology and industrial lasers. Technical and efficient solutions for our customers have been our focus since 1923. As a leading technology supplier, TRUMPF is a one-stop shop for all of your technology needs: machines, automation, storage technology and services.

TRUMPF is certified according to ISO 9001:2008
(for further information see www.trumpf.com/en/quality)

Ident no. 0372732-30-11-09-F -- Subject to change