



PRECISION ABRASIVE WATERJET SYSTEMS

Equipment Specifications

80X



OMAX® 80X JetMachining® Center

Designed for large scale precision machining of larger parts or multiple parts from stock up to 6'8" x 13'4" (2 m x 4 m).

The Model 80X JetMachining Center cuts complex flat parts out of most materials including metal, plastic, glass, ceramics, stone, and composites directly from a CAD drawing or .DXF file. It can also cut extremely hard, reflective and non-conductive materials, making it a valuable addition to existing shop capabilities. No tool changes or complex fixturing reduces setup times, and the smooth finish often eliminates the need for secondary machining.

80X

Standard Features

- OMAX Intelli-Max® software offers higher average cutting speeds and greater precision with free upgrades for the life of the machine
- Programmable Motorized Z-axis with precision OMAX MAXJET® 5 Nozzle Assembly
- Ballscrew drive inside the Y-axis bridge fully enclosed inside bellows
- Intelli-TRAX traction drive inside the X-axis beams fully enclosed inside coated steel covers
- Scissor-style hard plumbing
- Component protection against water, dirt, and grit
- High efficiency direct drive pump systems available in 30, 40, 60, 70 and 80 hp with pressures up to 55,000 psi
- Rapid Water Level Control for quiet and clean submerged cutting
- Bulk Abrasive Pump Assembly transports garnet from the assembly's large hopper into the small hopper located at the Z-axis
- Solids Removal System (SRS) designed for tough industrial use (available as an option)
- Tilt-A-Jet® taper compensating abrasivejet cutting head (available as an option)
- Shipped as a completely pre-assembled and factory-tested system

Abrasivejet Benefits

- Machines a wide range of materials and thicknesses
- Does not create heat-affected zones or mechanical stresses
- Rapid setup, no tool changes required
- Minimal fixturing required
- Leaves behind a satin-smooth edge, reducing secondary operations
- No noxious gases, liquids or oils used in (or caused by) the machining process
- Completes most work below 80 dBA for submerged cutting
- Environmentally "green" system with quiet and clean operation, low electrical and abrasive consumption



The OMAX Technology Guarantee entitles you, as the original owner, to free OMAX software upgrades for the life of the machine.

OMAX 80X JetMachining Center

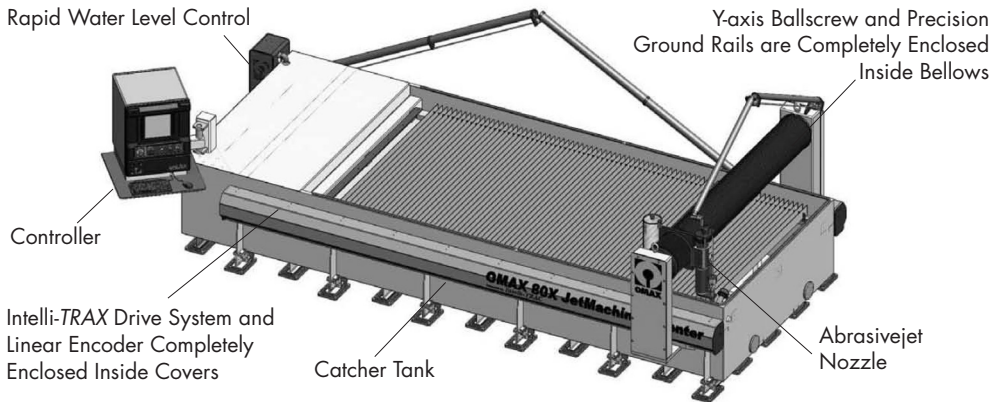

Options

- Dual Pump Package (redundant 30 hp or 40 hp option)
- Tilt-A-Jet Cutting Head for taper compensation
- Solids Removal System (SRS)
- Terrain Follower (TF)
- Z-axis Drill
- Precision Optical Locator (POL)
- Water-only MAXJET 5 for cutting soft materials
- OMAX MAXJET 5 MiniJet Nozzle Assembly
- Second MAXJET 5 with Motorized Z-axis and all necessary hard plumbing (Requires second Y-axis carriage)
- Manual Tilt Z
- Stone Cutting Kit
- Weir Tank
- Tall Slit Package
- Waterjet Brick Kit
- Catcher Tank Armor Plating

Machine Dimensions

Footprint (with Controller)	265" x 152"	(6731 mm x 3861 mm)
Weight (tank empty)	9000 lbs	(4050 kg)
Height	144"	(3658 mm)
Operating Weight	34,000 lbs	(15300 kg)

Work Envelope

X-Y Travel	165" x 80"	(4191 mm x 2032 mm)
Table Size	180" x 89"	(4572 mm x 2261 mm)
Material Support Slats	4" x 1/8" Galvanized Steel	
Maximum Supported Material Load	250 lbs/sq. ft.	(1,200 kg/sq. meter)

(Optional accessories may reduce travel. Contact OMAX for information.)

Computer Control System

Hardware	Personal computer
Control Software	Integrated CAD/CAM system directly uses .DXF files

Drive Description

- Closed loop, digital drives
- Brushless servo motors
- Pre-loaded ballscrew with recirculating ball bearings and hardened precision ground ways
- Bridge style Y-axis
- Intelli-TRAX Drive with linear encoder in X-axis
- Motor controlled precision Z-axis

Accuracy of Motion at 70° F

Ball Bar Circularity (Over 12")		
At Max. Traverse Velocity	±0.003"	(±0.076 mm)
Repeatability	±0.002"	(±0.051 mm)
Squareness	0.002" per foot	(0.17 mm/m)
Straightness	0.003" per foot	(0.25 mm/m)
Backlash	0.0007" maximum	(0.018 mm)

Speed

- 180 inches per minute standard (4572 mm/min)

Electrical Requirements

- 3-Phase, 380-480 VAC ±10%, 50-60 Hz
- (Note: Contact OMAX for detailed utility requirements. Pumps are built to meet UL and CE specifications.)*

Pump Options

- 30 horsepower, 50,000 psi (3500 bar)
- 40 horsepower, 55,000 psi (3850 bar)
- Dual Pump Package (redundant 30 hp or 40 hp)

Noise Level

- Below 80 dBA for submerged cutting

Note: Specifications subject to change without notice.

About OMAX

OMAX has the industry leading patented abrasivejet controller with a built-in expert system. Our exclusive "Compute First-Move Later" motion control system automates most programming and tool setup work, virtually eliminating the need for extensive operator training. Plus, with free OMAX Intelli-MAX® Software upgrades for life of the machine and our ongoing commitment to advance the efficiency of our technology and software, OMAX saves you time and money.

For information on what other OMAX products and accessories can do for you, call us today at 800-838-0343 or visit our website at www.omax.com.



OMAX

OMAX Corporation

21409 72nd Ave South, Kent, WA 98032
253-872-2300 **tel** 253-872-6190 **fax**
1-800-838-0343 **toll-free**
WWW.OMAX.COM website